



The three-layer formwork panels, made of solid wood, are made of three layers of spruce or fir wood that are glued together. The outer layer consists of wide glued slats, which run in length, while the middle layer consists of wooden sections that are configured transversely and are framed by the front and longitudinal rails. With this type of structure we obtain an adequate resistance to bending of the panel. A high quality water resistant glue is used (glued joints are tested according to the relevant standards). The surface is coated with yellow synthetic resin. Thanks to good surface and edge protection, the tiles can be safe for a long time.

## Description



### Technical details

Panel width: 500 mm  
 Panel length: 1500 - 3500 mm  
 Thickness: 21 mm (20.9 mm ± 1mm),  
 27 mm (26.9 mm ± 1mm)

Packing: 100 pieces / pallets - 21 mm,  
 80 pieces / pallets - 27 mm

## Example of use

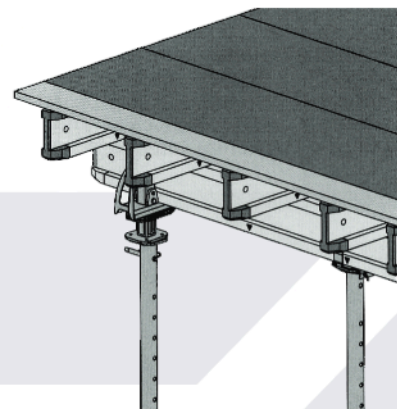

## Technical values

Formwork panel 21 mm:

Cross section	A brut = 20.900 mm <sup>2</sup> /m	MOE = 12.000 N/mm <sup>2</sup>
Torque resistance	W brut = 72.802 mm <sup>3</sup> /m	fm.k = 40 N/mm <sup>2</sup>
Lifting resistance	J brut = 760.777 mm <sup>4</sup> /m	Mk = 2.91 kNm/m
Outer layer	6.3 mm	
Middle layer	8.3 mm	

Formwork panel 27 mm:

Cross section	A brut = 26.600 mm <sup>2</sup> /m	MOE = 11.000 N/mm <sup>2</sup>
Torque resistance	W brut = 117.927 mm <sup>3</sup> /m	fm.k = 40 N/mm <sup>2</sup>
Lifting resistance	J brut = 1.568.425 mm <sup>4</sup> /m	Mk = 4.72 kNm/m
Outer layer	6.3 mm	
Middle layer	14 mm	

